

FACTORYSET
C2 Wiring
See page 6 for
other wiring
configurations

OWNER'S MANUAL

GH

INDUSTRIAL DUTY COMMERCIAL DOOR OPERATOR

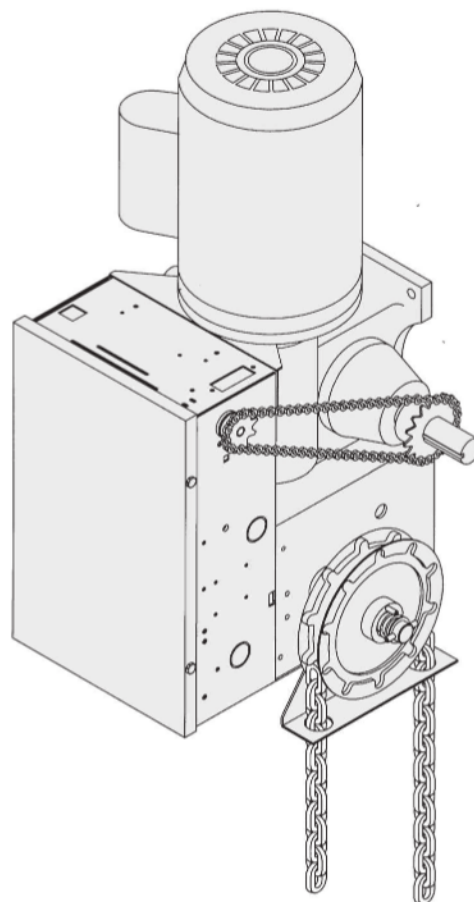

2 YEAR WARRANTY

Serial # Box _____

Installation Date _____

Wiring Type _____

NOT FOR RESIDENTIAL USE



TABLE OF CONTENTS

SPECIFICATIONS

Carton Inventory	3
Operator Dimensions	3
Operator Specifications	4

PREPARATION

Hand Chain Right/Left Conversion	5
Disconnect Lever Right/Left Conversion	5
Horizontal Mounting Conversion	5

INSTALLATION

Mount the Operator	6
Manual Operation	7
Entrapment Protection Accessories	8

ADJUSTMENT

Adjust Torque Limiter Clutch	9
Brake Adjustment	9

POWER WIRING

Power Wiring Connections	10
--------------------------------	----

CONTROL WIRING

Determine Wiring Type	11
Special Control Wiring	11
Mounting Instructions	11
Radio Controls	12
Additional Access Control Equipment	12
External Interlock Switch	12

TEST THE SYSTEM	12
------------------------------	----

DIAGRAMS

1 Phase Schematic Diagram	13
1 Phase Wiring Diagram	14
3 Phase Schematic Diagram	15
3 Phase Wiring Diagram	16

OPTIONAL PROGRAMMING

Connect Reversing Edge Device (Optional)	17
--	----

MAINTENANCE SCHEDULE	18
-----------------------------------	----

REPAIR PARTS

Repair Parts Kits - Electrical Box	20
Electrical Box	21
Repair Parts Kits - Model GH	22
Model GH	23
Control Connection Diagram	24

WARNING

Mechanical

WARNING

Electrical

CAUTION

When you see these Safety Symbols and Signal Words on the following pages, they will alert you to the possibility of **serious injury** or **death** if you do not comply with the warnings that accompany them. The hazard may come from something mechanical or from electric shock. Read the warnings carefully.

When you see this Signal Word on the following pages, it will alert you to the possibility of damage to your door and/or the door operator if you do not comply with the cautionary statements that accompany it. Read them carefully.

IMPORTANT NOTES:

- *BEFORE attempting to install, operate or maintain the operator, you must read and fully understand this manual and follow all safety instructions.*
- *DO NOT attempt repair or service of your commercial door and gate operator unless you are an Authorized Service Technician.*



WARNING: This product can expose you to chemicals including lead, which are known to the State of California to cause cancer or birth defects or other reproductive harm. For more information go to www.P65Warnings.ca.gov

CARTON INVENTORY

Before beginning your installation check that all components were provided.

DESCRIPTION

POWERHEAD ASSEMBLY
 OWNER'S MANUAL AND CAUTION LABELS
 HARDWARE BOX (INCLUDES FASTENERS, DISCONNECT AND CHAIN HOIST WALL BRACKET)
 3-BUTTON CONTROL STATION
 HOIST HAND CHAIN
 DOOR SPROCKET
 DOOR/OPERATOR DRIVE CHAIN

OPERATOR DIMENSIONS

WEIGHTS AND DIMENSIONS

HANGING WEIGHT: 80-110 LBS.

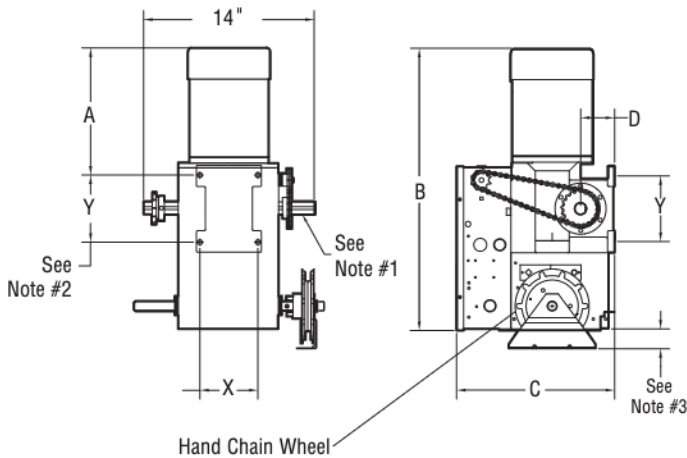

HP	PHASE	DIMENSIONS			
		A	B	C	D
1/2	1	11-1/2"	25-3/4"	12-63/64"	3"
3/4	1	12-1/2"	26-3/4"	12-63/64"	3"
1	1	12-3/4"	27"	12-63/64"	3"
1-1/2	1	12-3/4"	27"	13-63/64"	3-1/2"
1/2	3	11"	25-1/4"	12-63/64"	3"
3/4	3	11"	25-1/4"	12-63/64"	3"
1	3	12"	26-1/4"	12-63/64"	3"
1-1/2	3	12-1/2"	26-3/4"	13-63/64"	3-1/2"
2	3	12-3/4"	27"	13-63/64"	3-1/2"
3	3	13-1/4"	28-5/8"	15-15/64"	3-15/16"

NOTES:

- 1) Output shaft with 1" x 1/4" key for 1/2 thru 1HP operators, 1-3/16" x 5/16" key for 1-1/2 and 2 HP operators, 1-1/4" x 1/4" key for 3HP operators.
- 2) Mounting Centers: X = 4-3/4"; Y = 5-1/2" for 1/2 thru 2HP operators
 X = 7-17/32"; Y = 9-1/16" for 3HP operators
- 3) Hand Chain Wheel extends 1-5/8" beyond operator in vertical mounting position as shown.

PREPARATION

It is imperative that the wall or mounting surface provide adequate support for the operator.

This surface must:

- Be rigid to prevent play between operator and door shaft.
- Provide a level base.
- Permit the operator to be fastened securely and with the drive shaft parallel to the door shaft.

The safety and wear of the operator will be adversely affected if any of the above requirements are not met. For metal buildings, fasten 2" x 2" x 3/16" (or larger) angle iron frames to the building purlins. Retain 5-1/2" (13.97 cm) between frames.

The GH operator may be mounted on either the right (standard) or left side of door, and in either a vertical (standard) or horizontal mounting position. Refer to the steps below if you require the hand chain and/or disconnect chain to be on the opposite side of the operator; or if the operator is being mounted in a horizontal position.

HAND CHAIN RIGHT/LEFT CONVERSION

Remove the two snap rings (1 piece outer, 1 piece inner) on hand chain shaft assembly. Position roll-pin to fit through cutout in frame and slide complete shaft assembly through housing and bevel gear. Insert shaft assembly on opposite side of housing, and replace bevel gear, bearing, hardware, and snap rings on the opposite side of shaft in the same manner.

DISCONNECT LEVER RIGHT/LEFT CONVERSION

Remove cotterpins on the ends of the disconnect shaft (square shaft), move the disconnect lever arm to the opposite side, and replace the cotterpins. Be sure to keep 12 gauge washers (2) on the side without the lever arm.

HORIZONTAL MOUNTING CONVERSION

Remove cotterpins on the ends of the disconnect shaft (square shaft), and remove lever. Replace lever using square hole on opposite end of lever. Reposition sash chain to opposite end of lever also. Replace cotterpins.

⚠️ WARNING

To prevent possible **SERIOUS INJURY** or **DEATH**:

- **DO NOT** connect electric power until instructed to do so.
- If the door lock needs to remain functional, install an interlock switch.
- **ALWAYS** call a trained professional door serviceman if door binds, sticks or is out of balance. An unbalanced door may not reverse when required.
- **NEVER** try to loosen, move or adjust doors, door springs, cables, pulleys, brackets or their hardware, **ALL** of which are under **EXTREME** tension and can cause **SERIOUS** personal **INJURY**.
- Disable **ALL** locks and remove **ALL** ropes connected to door **BEFORE** installing and operating door operator to avoid entanglement.

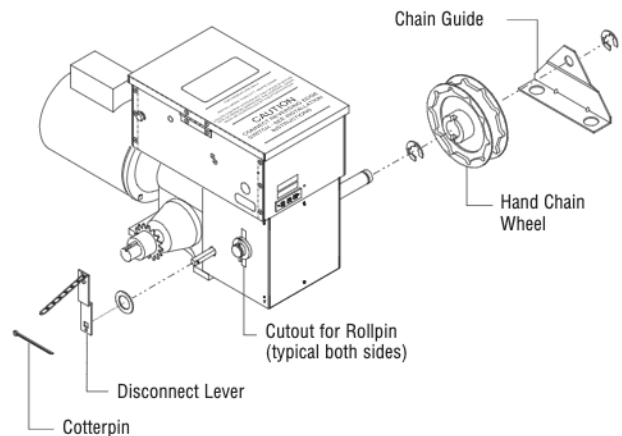
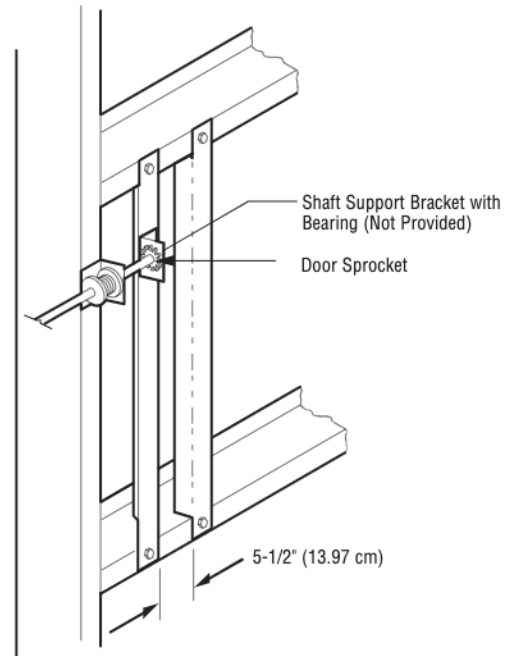

INSTALLATION

IMPORTANT NOTE: Before your operator is installed, be sure the door has been properly aligned and is working smoothly. The operator may be wall mounted or mounted on a bracket or shelf. If necessary, refer to the preparation on page 5. Refer to the illustrations and instructions below that suit your application.

MOUNT THE OPERATOR

1. **Wall Mount:** The operator should generally be installed below the door shaft, and as close to the door as possible (Figure 1).

Bracket Shelf Mounting: The operator may be mounted either above or below the door shaft (Figure 2).

IMPORTANT: The shelf or bracket must provide adequate support, prevent play between operator and door shaft, and permit operator to be fastened securely and with the drive shaft parallel to the door shaft.

NOTE: The optimum distance between the door shaft and operator drive shaft is between 12" - 15" (30.5 - 38.1 cm).

2. Place door sprocket on the door shaft. Do not insert the key at this time.
3. Place drive sprocket on the appropriate side of the operator. Do not insert the key at this time.
4. Wrap drive chain around door sprocket and join roller chain ends together with master link.
5. Raise operator to approximate mounting position and position chain over operator sprocket.
6. Raise or lower operator until the chain is taut (not tight). Make sure the operator output shaft is parallel to door shaft and sprockets are aligned. When in position, secure the operator to wall or mounting bracket.
7. Align sprockets and secure (Figure 3).

8. Install Hand Chain

Place hand chain around hand chain wheel. Be sure to pass it through both openings in the chain guide. Remove enough links so chain hangs approximately 2' (.61 m) above the floor.

9. Mount Chain Keeper / Keyhole Bracket

Using suitable hardware mount the chain keeper approximately 4' (1.22 m) above the floor, near the free hanging chain. Remove disconnect sash chain from bag and place the end through the keyhole in the the chain keeper. Remove excess links if necessary.

Figure 1

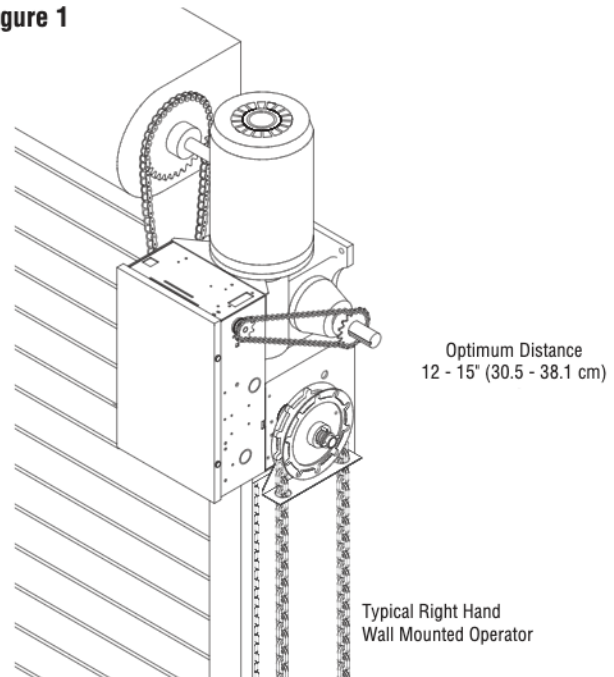

Figure 2

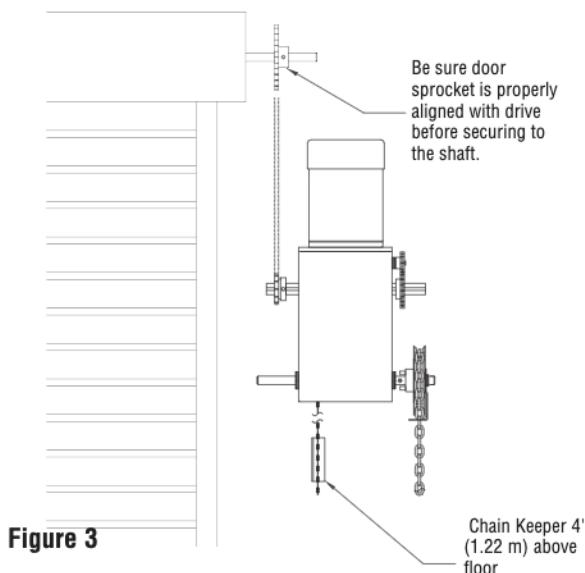
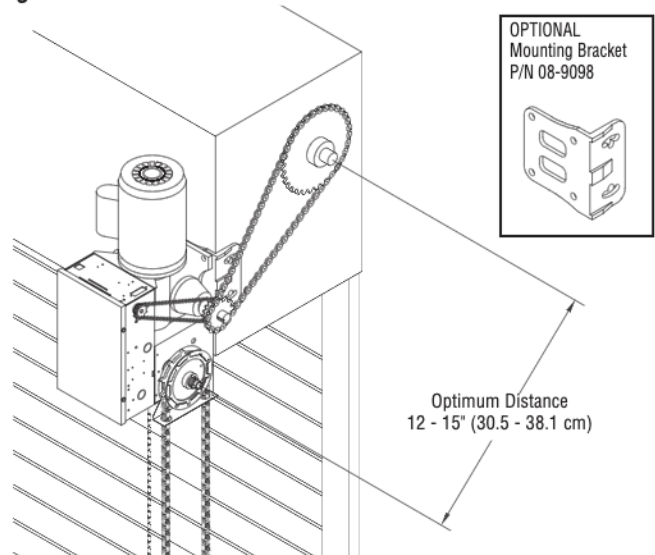

Figure 3

INSTALLATION

MANUAL OPERATION

This operator has provisions for manually operating the door in case of emergency or power failure. These operators are equipped with a manual hoist. An electrical interlock will disable the electrical controls when the hoist is used.

To operate the hoist:

1. Pull the disconnect chain (small chain) to engage the interlock to disable the controls. The disconnect chain may be locked in position by slipping the end through the keyhole of the chain keeper mounted on the wall.
2. Operate the door in the desired direction by pulling on one side or the other of the continuous loop hoist chain (large chain).
3. The disconnect chain must be released from the chain keeper before the door will operate again electrically.

⚠ WARNING

To prevent possible **SERIOUS INJURY** from a moving chain, **ENGAGE** interlock **BEFORE** manually operating your door.

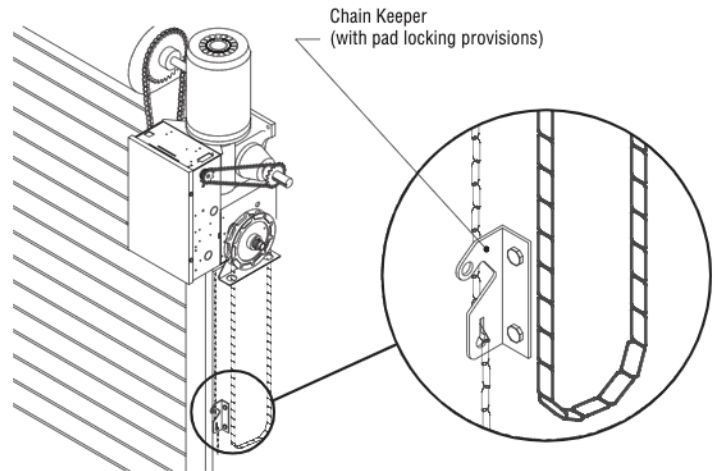

INSTALLATION

ENTRAPMENT PROTECTION ACCESSORIES (OPTIONAL)

PHOTO EYES & SENSING EDGES

Sensing devices provided for door industry type operators with an isolated normally open (N.O.) dry contact output are compatible with your operator. This includes pneumatic and electric edges, and through beam and retro reflective photo eyes. If you would like to order or receive more information on safety devices, please contact your local Authorized Dealer.

If not pre-installed by the door manufacturer, mount the sensing edge on the door according to the instructions provided with the edge. The sensing edge may be electrically connected by either coiled cord or take-up reel.

IMPORTANT NOTES:

- Proceed with limit switch adjustments described below before making any sensing edge wiring connections to operator.
- Electrician must hardwire the junction box to the operator electrical box in accordance with local codes.

⚠ WARNING

To reduce the risk of SEVERE INJURY or DEATH, ALWAYS install reversing sensors when the 3-button control station is out of sight of door or ANY other control (automatic or manual) is used. Reversing devices are recommended for ALL installations.

WIRING

For wiring of your sensing device to the operator, refer to the wiring diagrams provided on pages 13 and 14. See field connection terminals identified as sensing device or safety edge.

TAKE-UP REEL

Take-up reel should be installed 12" (30.48 cm) above the top of the door.

COIL CORD

Connect operator end of coil cord to junction box (not provided) fastened to the wall approximately halfway up the door opening.

ADJUSTMENT

LIMIT SWITCH ADJUSTMENT

NOTE: Make sure the limit nuts are positioned between the limit switches before proceeding with adjustments.

- Depress retaining plate to allow nut to spin freely. After adjustment, release plate and move nut back and forth to ensure it is fully seated in slot.
- To **increase** door travel, spin nut **away** from limit switch. To **decrease** door travel, spin limit nut **toward** limit switch.
- Adjust open limit nut so that door will stop in open position with the bottom of the door even with top of door opening.
- Repeat steps 1 and 2 for close cycle. Adjust close limit nut so that the limit switch is engaged as door fully seats at the floor.

⚠ ⚠ WARNING

To avoid SERIOUS personal INJURY or DEATH from electrocution, disconnect electric power BEFORE manually moving limit nuts.

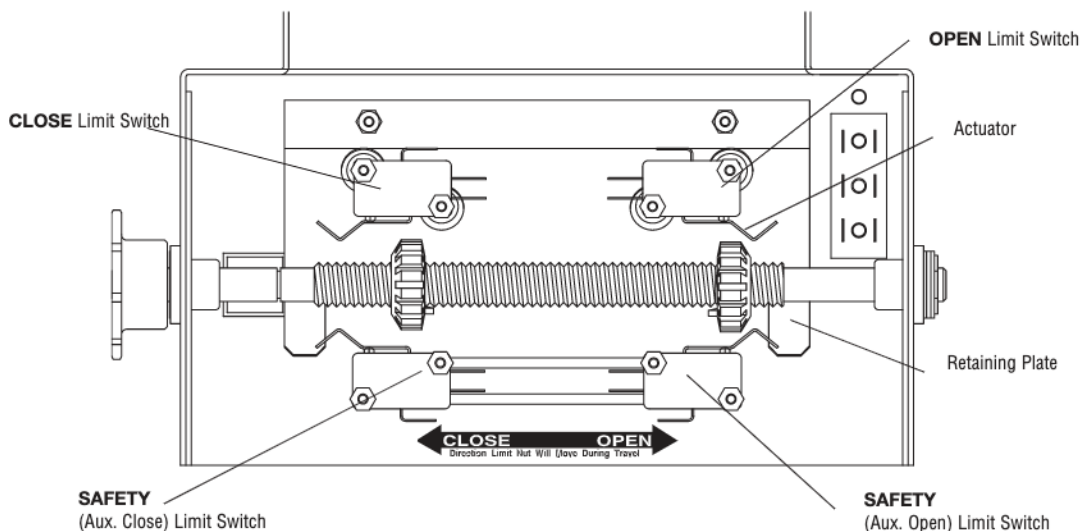

ADJUSTMENT

ADJUST TORQUE LIMITER CLUTCH (OPTIONAL MODIFICATION)

1. Loosen set screws on clutch nut.
2. Back off clutch nut until there is very little tension on the clutch spring.
3. Tighten clutch nut gradually until there is just enough tension to permit the operator to move the door smoothly but to allow the clutch to slip if the door is obstructed. When the clutch is properly adjusted, it should generally be possible to stop the door by hand during travel.

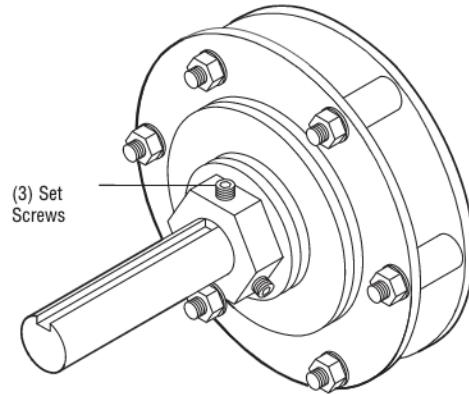

BRAKE ADJUSTMENT

The brake is adjusted at the factory and should not need additional adjustment for the the life of the brake assembly.

Replace brake assembly when necessary. Refer to the illustration for identification of components for the solenoid type brake system.

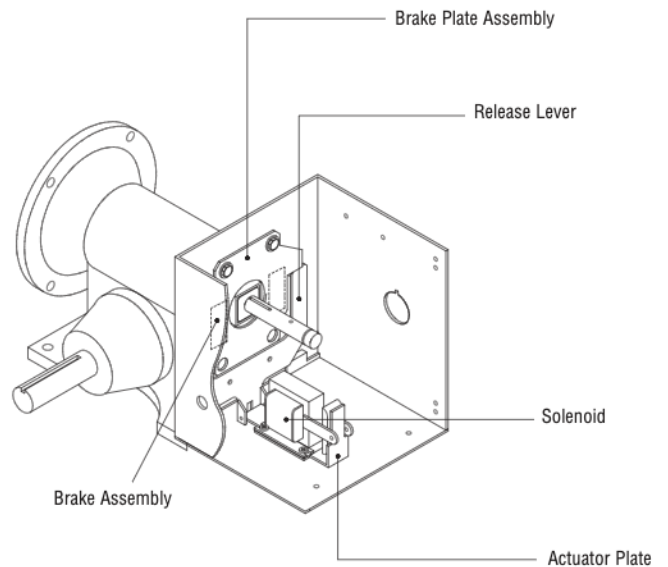

POWER WIRING

WARNING

To reduce the risk of SEVERE INJURY or DEATH:

- ANY maintenance to the operator or in the area near the operator MUST NOT be performed until disconnecting the electrical power and locking-out the power via the operator power switch. Upon completion of maintenance the area MUST be cleared and secured, at that time the unit may be returned to service.
- Disconnect power at the fuse box BEFORE proceeding. Operator MUST be properly grounded and connected in accordance with local electrical codes. The operator should be on a separate fused line of adequate capacity.
- ALL electrical connections MUST be made by a qualified individual.
- DO NOT install ANY wiring or attempt to run the operator without consulting the wiring diagram. We recommend that you install an optional reversing edge BEFORE proceeding with the control station installation.
- ALL power wiring should be on a dedicated circuit and well protected. The location of the power disconnect should be visible and clearly labeled.
- ALL power and control wiring MUST be run in separate conduit.

POWER WIRING CONNECTIONS

Remove the cover from the electrical enclosure. Inside this enclosure you will find the wiring diagram(s) for your unit. Refer to the diagram (glued on the inside of the cover) for all connections described below. If this diagram is missing, call the number on the back of this manual. **NOTE:** Do not install any wiring or attempt to run this operator without consulting the wiring diagram.

1. Be sure that the power supply is of the correct voltage, phase, frequency, and amperage to supply the operator. Refer to the operator nameplate on the cover.
2. Using the 1-1/16" dia conduit access knockout as shown below, bring supply lines to the operator and connect wires to the terminals indicated on the WIRING CONNECTIONS DIAGRAM.

NOTE: Do not turn power on until you have finished making all power and control wiring connections and have completed the limit switch adjustment procedure.

IMPORTANT NOTE: This unit must be properly grounded. Failure to properly ground this unit could result in electric shock and serious injury.

CONDUIT ACCESS

1-1/16" Diameter knockout for power wiring conduit access (1 nearside)

7/8" Diameter knockout for power wiring conduit access (2 on end panel)

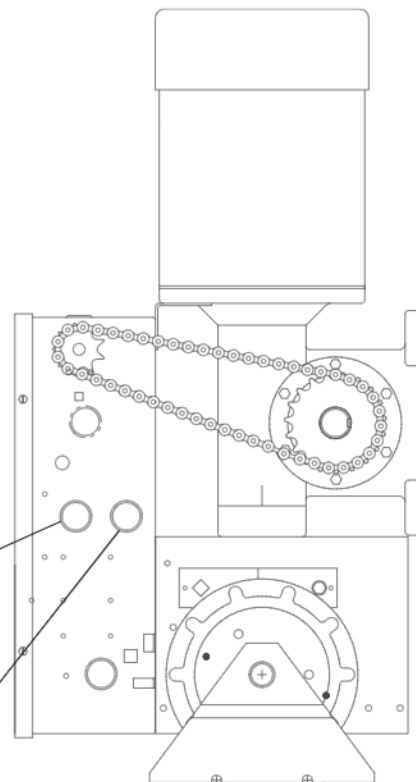

CONTROL WIRING

DETERMINE WIRING TYPE

Refer to the wiring diagram located on the inside cover the electrical box to determine the type of control wiring.

IMPORTANT NOTE: If your wiring diagram is missing, or you are unsure of the wiring type for your operator, contact the customer service department: 1-800-528-2806.

STANDARD C2 OR B2 WIRING

Standard operators are shipped from the factory with jumper set for C2 wiring, which requires constant pressure on button to close the door. If momentary contact on close direction is desired (B2 wiring) you must include an entrapment protection device. See close control jumper setting below.

CONSTANT PRESSURE ON CLOSE (C2 WIRING)

Red jumper wire was placed on terminal #2 in electrical enclosure. The operator will require constant pressure on close control in order to keep door moving in the close direction.

MOMENTARY CONTACT ON CLOSE (B2 WIRING)

Move red jumper wire from terminal #2 to terminal #3. The operator will require only momentary contact to close the door.

SPECIAL CONTROL WIRING

If your operator was shipped from the factory with non-standard control wiring or with optional accessories that require addition instructions, refer to the wiring diagram(s) indicated in the special control wiring data box. When a replacement wiring diagram is present, wiring diagrams in this manual will not apply. Refer only to the replacement wiring diagram for all connections.

RADIO CONTROLS

On all models with type B2 control wiring, a terminal bracket marked R1 R2 R3 is located on the outside of the electrical enclosure. All standard radio control receivers (single channel residential type) may be mounted to this bracket. The operator will then open a fully closed door, close a fully open door, and reverse a closing door from the radio transmitter. However, for complete door control from a transmitter, a commercial three-channel radio set (with connections for Open/Close/Stop) is recommended.

ADDITIONAL ACCESS CONTROL EQUIPMENT

Locate any additional access control equipment as desired (but so that the door will be in clear sight of the person operating the equipment), and connect to the terminal block in the electrical enclosure as shown on the Field Wiring Connections diagram. Any control with a normally (N.O.) isolated output contact may be connected in parallel with the OPEN button. More than one device may be connected in this manner. Use 16 gauge wire or larger for all controls. Do not use the Control Circuit Transformer (24 Vac) in the Operator to power any access control equipment other than a standard residential type radio receiver.

EXTERNAL INTERLOCK SWITCH

The operator has a terminal connection for an external interlock switch. This switch must be a normally closed (N.C.) two-wire device with a contact rating of at least 3 amps at 24 Vac. When

! WARNING

To prevent possible **SERIOUS INJURY** or **DEATH**, install reversing sensors when the 3-button control station is out of sight of the door or **ANY** other control (automatic or manual) is used. Reversing devices are recommended for **ALL** installations.

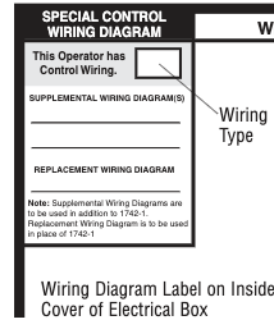

such a switch is connected as shown on the Field Wiring Connections diagram, the control circuit will be disabled when the switch is actuated, thereby preventing electrical operation of the door from the control devices.

MOUNTING INSTRUCTIONS

1. Mount **WARNING NOTICE** beside or below the control station.
2. Mount **MAINTENANCE ALERT** label to either side of control station.
3. Mount control station(s) within line of sight of door(s).

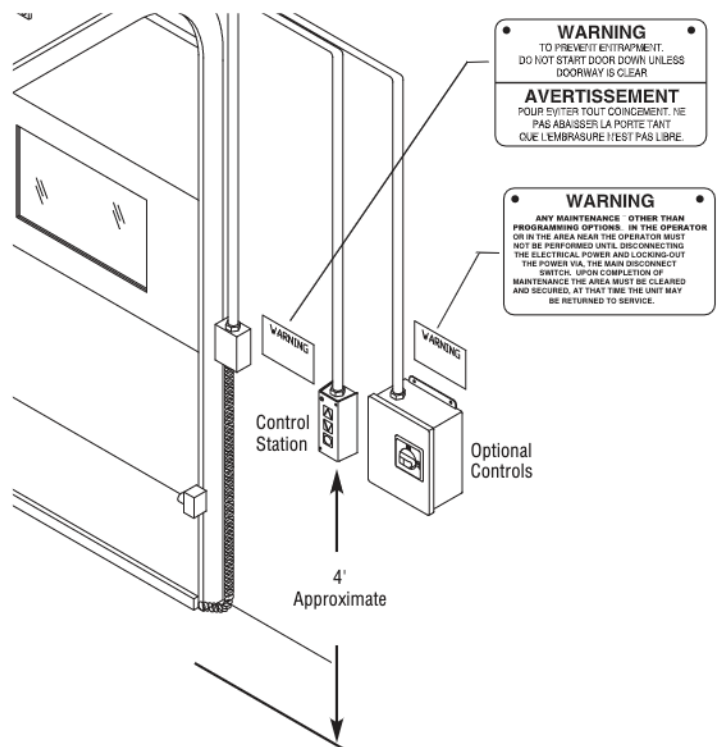

CONTROL WIRING (CONT'D)

RADIO CONTROLS

On all models with type B2 control wiring, a terminal bracket marked R1 R2 R3 is located on the outside of the electrical enclosure. All standard radio control receivers (single channel residential type) may be mounted to this bracket. The operator will then open a fully closed door, close a fully open door, and reverse a closing door from the radio transmitter. However, for complete door control from a transmitter, a commercial three-channel radio set (with connections for OPEN/CLOSE/STOP) is recommended.

ADDITIONAL ACCESS CONTROL EQUIPMENT

Locate any additional access control equipment as desired (but so that the door will be in clear sight of the person operating the equipment), and connect to the terminal block in the electrical enclosure as shown on the FIELD WIRING CONNECTIONS diagram. Any control with a normally (N.O.) isolated output contact may be connected in parallel with the OPEN button. More than one device may be connected in this manner. Use 16 gauge wire or larger for all controls. **NOTE:** *Do not use the control circuit transformer (24Vac) in the operator to power any access control equipment other than a standard residential type radio receiver.*

WARNING

DO NOT use radio controls with your operator unless you have installed some type of entrapment protection device. The use of radio controls presents potential hazards due to the user's ability to open or close the door when out of sight of the door. In addition, if a single channel control is used, the user will not be able to stop the door from the remote control.

EXTERNAL INTERLOCK SWITCH

The operator has a terminal connection for an external interlock switch. This switch must be a normally closed (N.C.) two-wire device with a contact rating of at least 3 amps at 24 Vac. When such a switch is connected as shown on the FIELD WIRING CONNECTIONS diagram, the control circuit will be disabled when the switch is actuated, thereby preventing electrical operation of the door from the control devices.

TEST THE SYSTEM

Turn on power. Test all controls and safety devices to make sure they are working properly. It will be necessary to refer back to page 6 for fine adjustment of the limit switches.

IMPORTANT NOTES:

- *Do not leave operator power on unless all safety and entrapment protection devices have been tested and are working properly.*
- *Be sure you have read and understand all Safety Instructions included in this manual.*
- *Be sure the owner or person(s) responsible for operation of the door have read and understand the Safety Instructions, know how to electrically operate the door in a safe manner, and know how to use the manual disconnect operation of the door operating system.*

WARNING

DO NOT place hands or tools in or near the operator when the power is on or when testing control or safety devices. ALWAYS disconnect power BEFORE servicing or adjusting the operator.

SINGLE PHASE SCHEMATIC DIAGRAM • 10118-1

WARNING

Always Disconnect Power Whenever Installing or Servicing the Door Operator.

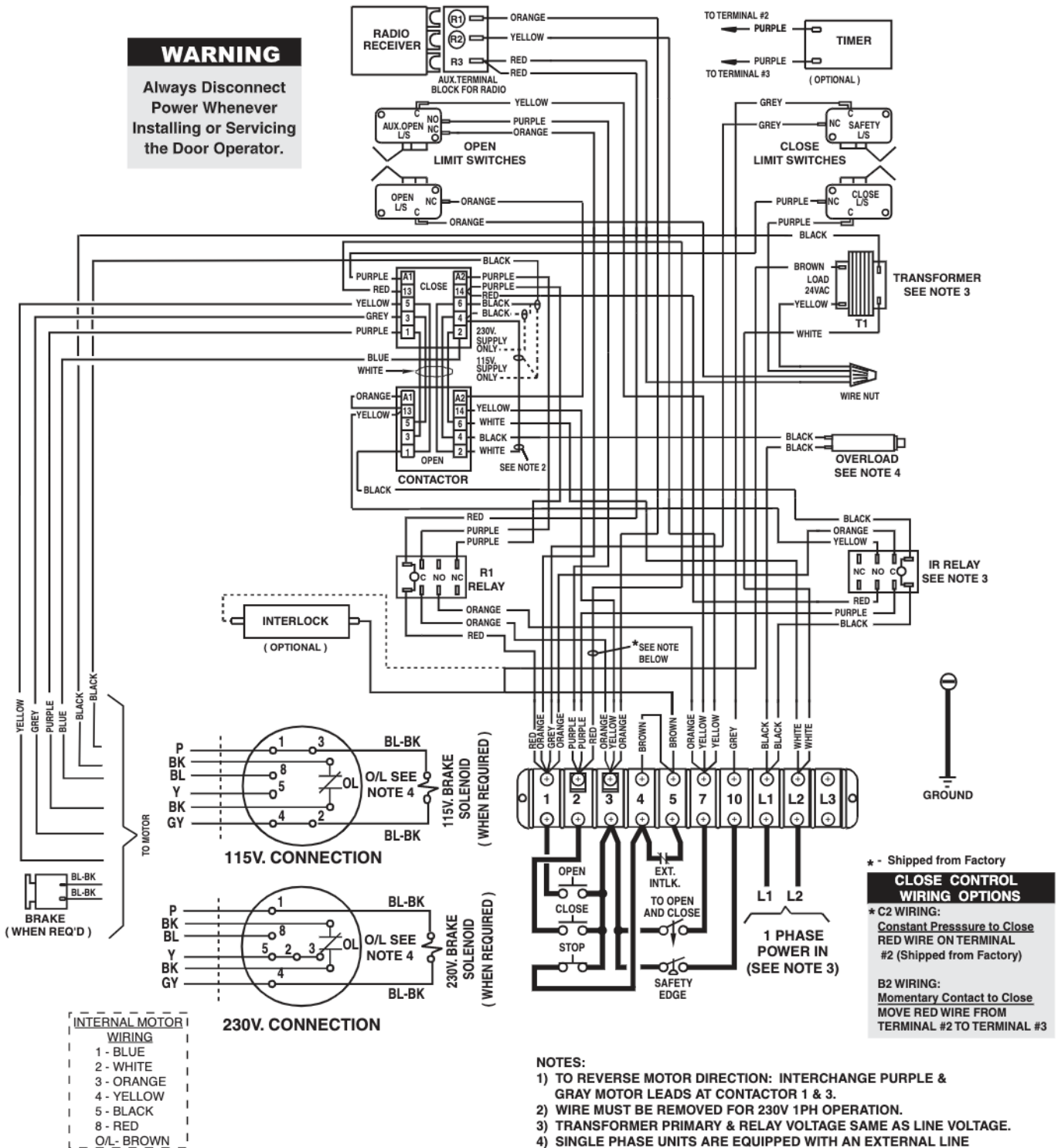

SINGLE PHASE WIRING DIAGRAM • 10118-1

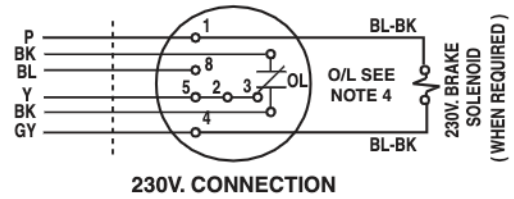
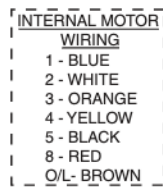
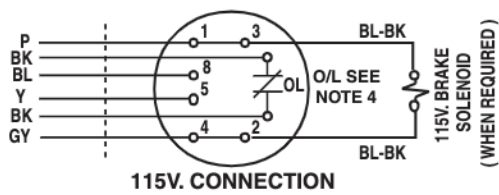

WARNING
Always Disconnect Power Whenever Installing or Servicing the Door Operator.

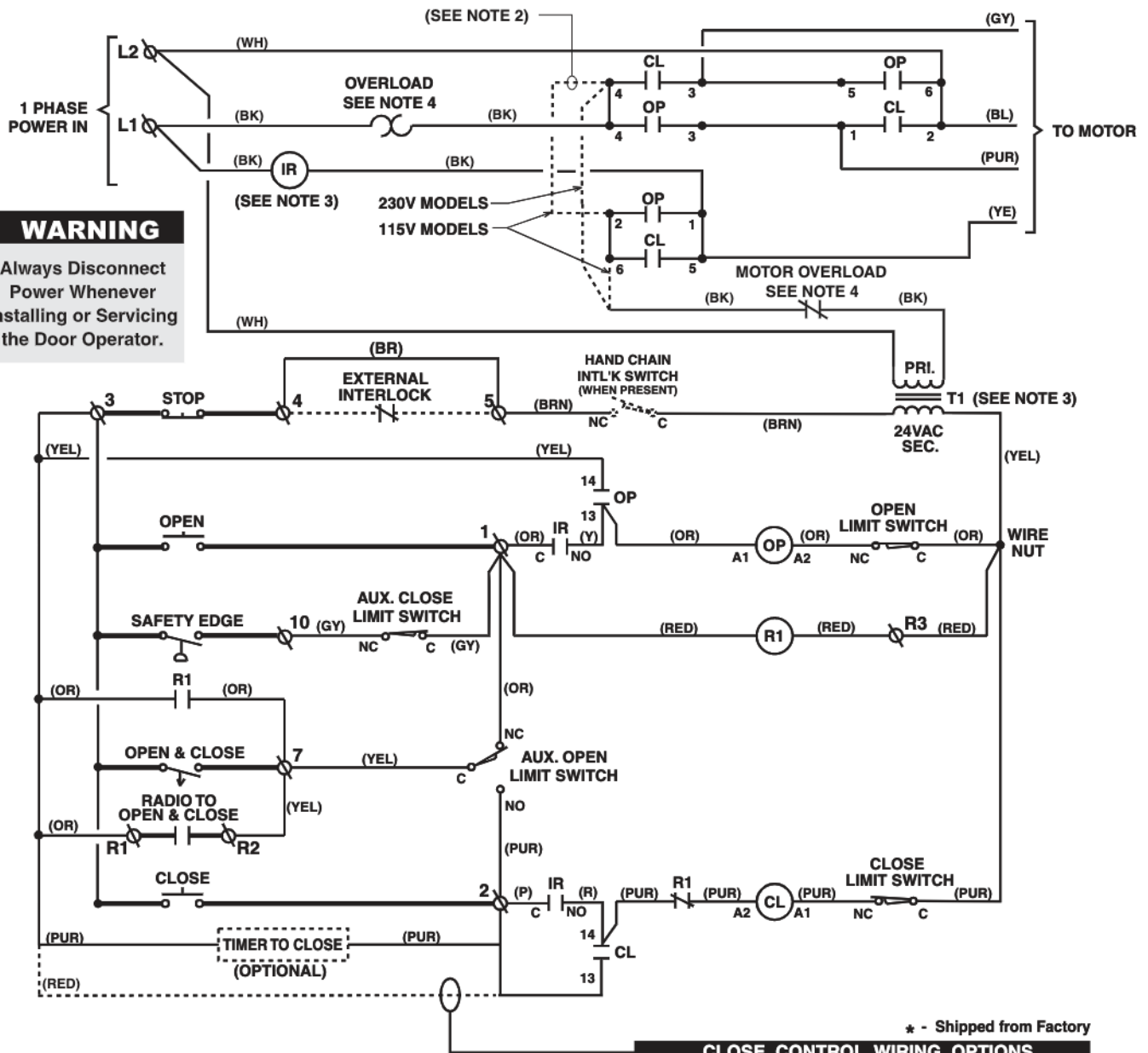

* - Shipped from Factory

CLOSE CONTROL WIRING OPTIONS

- *C2 WIRING - Constant Pressure to Close
RED WIRE ON TERMINAL #2 (Shipped from Factory)
- B2 WIRING - Momentary Contact to Close
MOVE RED WIRE FROM TERMINAL #2 TO TERMINAL #3

- NOTES:
- 1) TO REVERSE MOTOR DIRECTION: INTERCHANGE PURPLE & GRAY MOTOR LEADS AT CONTACTOR 1 & 3.
 - 2) WIRE MUST BE REMOVED FOR 230V 1PH OPERATION.
 - 3) TRANSFORMER PRIMARY & RELAY VOLTAGE SAME AS LINE VOLTAGE.
 - 4) SINGLE PHASE UNITS ARE EQUIPPED WITH AN EXTERNAL LINE BREAK DEVICE, AND MAY BE EQUIPPED WITH AN ADDITIONAL INTERNAL PILOT DUTY THERMAL O/L DEVICE.

THREE PHASE SCHEMATIC DIAGRAM • 10118-3

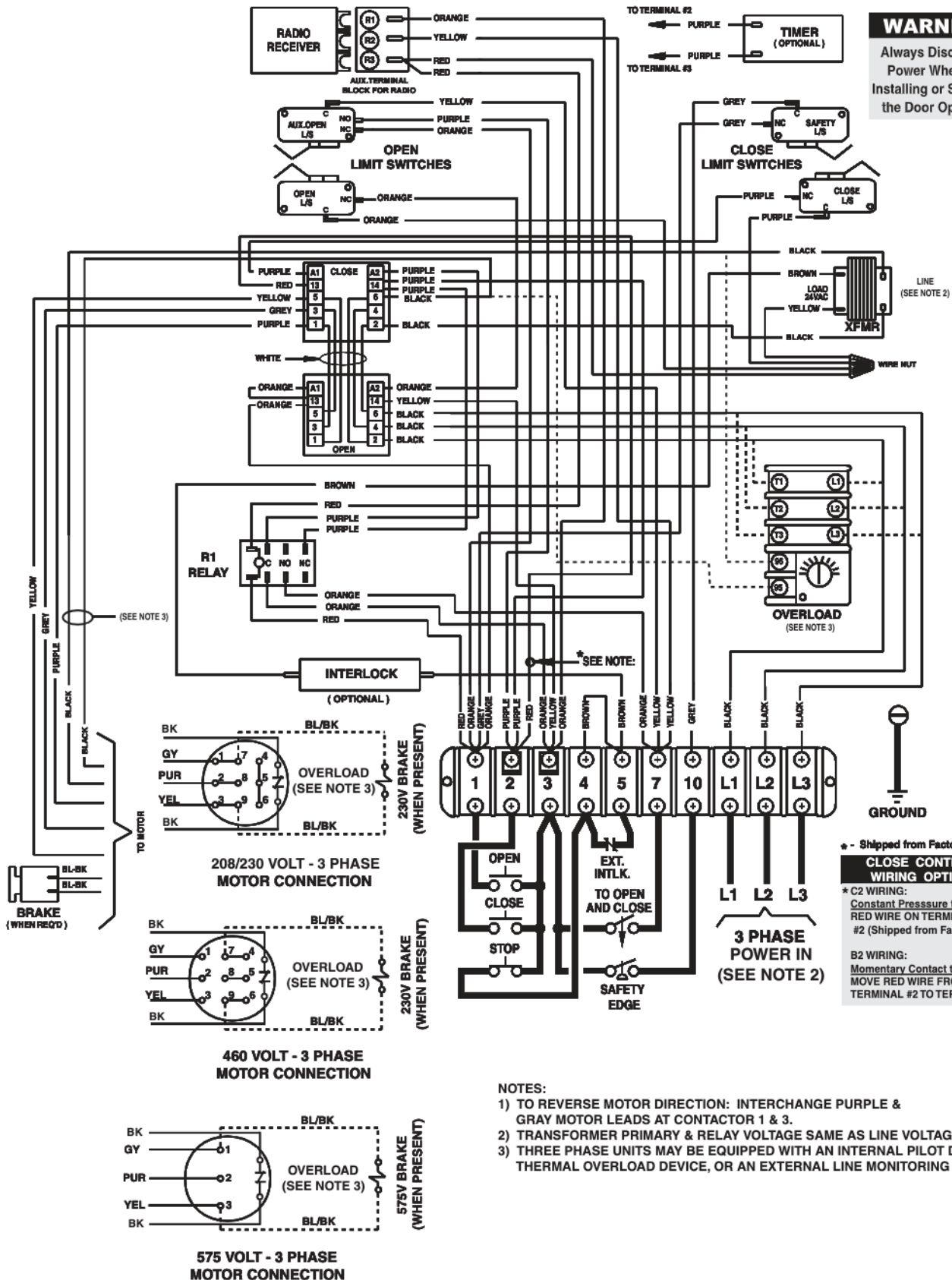

THREE PHASE WIRING DIAGRAM • 10118-3

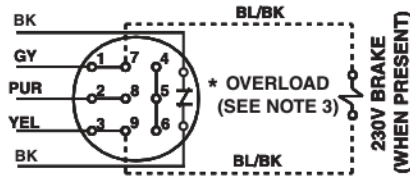

208/230 VOLT - 3 PHASE MOTOR CONNECTION

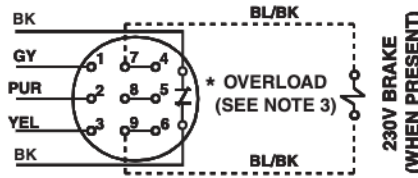

460 VOLT - 3 PHASE MOTOR CONNECTION

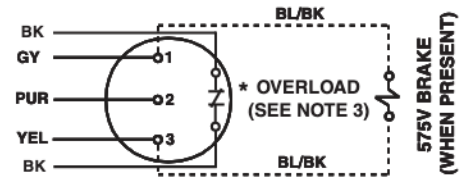

575 VOLT - 3 PHASE MOTOR CONNECTION

* MOTOR O/L LEAD COLOR BROWN

WARNING
Always Disconnect Power Whenever Installing or Servicing the Door Operator.

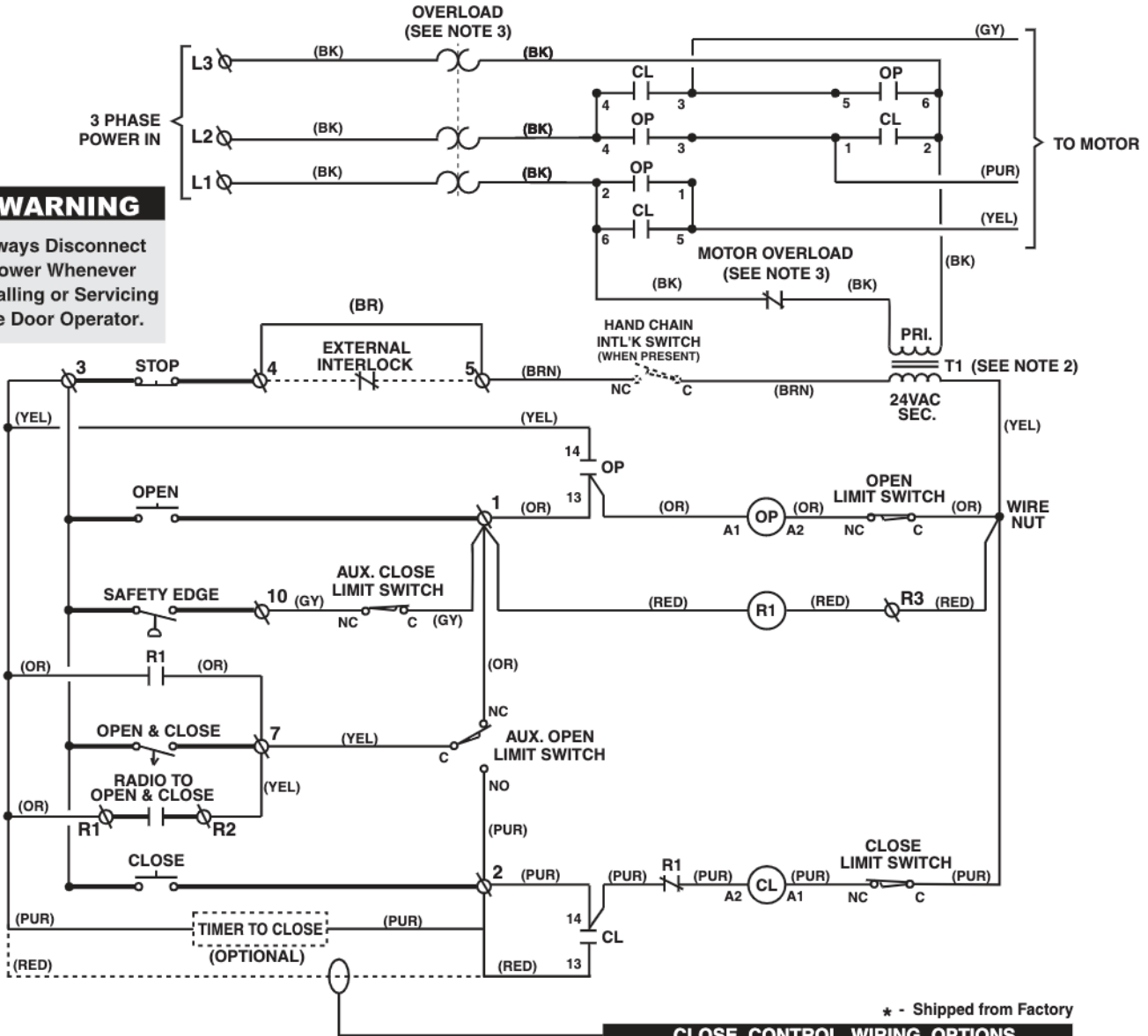

* - Shipped from Factory
CLOSE CONTROL WIRING OPTIONS
*C2 WIRING - Constant Pressure to Close
RED WIRE ON TERMINAL #2 (Shipped from Factory)
B2 WIRING - Momentary Contact to Close
MOVE RED WIRE FROM TERMINAL #2 TO TERMINAL #3

- NOTES:
- 1) TO REVERSE MOTOR DIRECTION: INTERCHANGE PURPLE & GRAY MOTOR LEADS AT CONTACTOR 1 & 3.
 - 2) TRANSFORMER PRIMARY & RELAY VOLTAGE SAME AS LINE VOLTAGE.
 - 3) THREE PHASE UNITS MAY BE EQUIPPED WITH AN INTERNAL PILOT DUTY THERMAL OVERLOAD DEVICE, OR AN EXTERNAL LINE MONITORING DEVICE.

OPTIONAL PROGRAMMING

CONNECT REVERSING EDGE DEVICE (OPTIONAL)

The operator has been pre-wired to accept connection of a reversing edge device. Connect the normally open contacts to terminals T4 and T8 on the low voltage terminal block. A cut-off switch will de-activate the safety device during the last few inches of the door's downward travel.

WARNING

If control station cannot be installed where door is visible, or if ANY device other than the control station is used to activate the door, a reversing edge **MUST** be installed on the bottom of the door. Failure to install a reversing edge under these circumstances may result in **SERIOUS** personal **INJURY** or **DEATH** to persons trapped beneath the door.

NOTICE: This equipment has been tested and found to comply with the limits for a Class A digital device, pursuant to Part 15 of the FCC Rules. These limits are designed to provide reasonable protection against harmful interference when the equipment is operated in a commercial environment. This equipment generates, uses, and can radiate radio frequency energy and, if not installed and used in accordance with the instruction manual, may cause harmful interference to radio communications. Operation of this equipment in a residential area is likely to cause harmful interference, in which case the user will be required to correct the interference at his own expense.

MAINTENANCE SCHEDULE

Check at the intervals listed in the following chart:

ITEM	PROCEDURE	EVERY 3 MONTHS OR 5,000 CYCLES	EVERY 6 MONTHS OR 10,000 CYCLES	EVERY 12 MONTHS OR 20,000 CYCLES
Drive Chain	Check for excessive slack. Check and adjust as required. Lubricate.	●●		◆
Sprockets	Check set screw tightness.	●		◆
Fasteners	Check and tighten as required.		●	◆
Manual Disconnect	Check and operate.		●	◆
Bearings and Shafts	Check for wear and lubricate.	●●		◆

WARNING

To avoid **SERIOUS** personal **INJURY** or **DEATH** from electrocution, disconnect **ALL** electric power **BEFORE** performing **ANY** maintenance.

- ◆ **Use SAE 30 Oil (Never use grease or silicone spray).**
 - Do not lubricate motor. Motor bearings are rated for continuous operation.
 - Do not lubricate clutch or V-belt.
- ◆ **Repeat ALL procedures.**
- Inspect and service whenever a malfunction is observed or suspected.

HOW TO ORDER REPAIR PARTS

OUR LARGE SERVICE ORGANIZATION SPANS AMERICA

Installation and service information are available.

Call our TOLL FREE number:

1-800-528-2806

www.liftmaster.com

This page intentionally left blank.

REPLACEMENT PART KITS - ELECTRICAL BOX

INDIVIDUAL PARTS

ITEM	PART#	DESCRIPTION
1	03-8024-K	Contactora
2	10-10020M1	Electrical Box (For Models T, J & H)
3	10-10115X	Electrical Box Cover
4	21-5115	Transformer, 115V Operators
	21-5230	Transformer, 230V Operators
	21-5460	Transformer, 380-460V Operators
5	23-10916	SPDT Interlock Switch
6	24-24-1	24VAC DPDT Relay
7	24-115-1	Relay, 115 Volts
	24-230-5	Relay, 230 Volts
8	25-2006	Overload 6 Amp
	25-2008	Overload 8 Amp
	25-2010	Overload 10 Amp
	25-2015	Overload 15 Amp
	25-2020	Overload 20 Amp
9	25-4002-5K	Overload 1.6-2.5 Amp
	25-4003-K	Overload 2.6-3.7 Amp
	25-4004-K	Overload 2.5-4.0 Amp
	25-4008-K	Overload 5.5-8.0 Amp
	25-4011-5K	Overload 8.0-11.5 Amp
10	42-10040	Terminal Block, Radio
11	42-110	Terminal Block, 10 Position
12	25-3000-K	Overload Bracket

NOT SHOWN

K72-14130 Cube Style Limit Shaft

K72-12510 LIMIT SHAFT ASSEMBLY KIT

ITEM	PART #	DESCRIPTION	QTY
L1	11-10021	Limit Shaft, Standard T	1
L2	12-10028	Flange Bearing, 3/8" I.D.	2
L3	13-10024	Limit Nut	2
L4	15-48B9AXX	Sprocket 48B9 x 3/8" Bore	1
L5		Washer, Shim 3/8" I.D. x .050 THK.	1
L6		Washer, Shim 3/8" I.D. x .010 THK.	1
L7	86-RP04-100	Roll Pin, 1/8 DIA. x 1 Long	1
L8	87-E-038	E Ring, 3/8"	1

K75-12511 LIMIT SWITCH ASSEMBLY KIT

ITEM	PART #	DESCRIPTION	QTY
S1		Depress Plate	1
S2		Nut Plate, Switch	4
S3		Backup Plate	2
S4		Spring, Depress Plate	2
S5	23-10041	Limit Switch	4
S6		Standoff, Limit Switch,	4
S7		Screw, #4-40 Pan Head Phillips	8
S8		Screw, #6-32 x 1" Pan Hd Phillips	2
S9		Locknut, #6-32 Nylon Hex	2

COMPLETE ELECTRICAL BOX REPLACEMENT KITS

To order a complete electrical box replacement kit, add a K- Prefix to the model number of your operator for example:
T5011M (Operator) = K-T5011M (Electrical Box Kit)

PART#	DESCRIPTION
Electrical Box Sub-Assemblies	
K72-12510	Limit Shaft Assembly
K75-12511	Limit Switch Assembly

Individual Component Kits

21-5575	Transformer, 575V Operators
24-115-1	Relay, 115V 1Ph Operators
24-230-5	Relay, 230V 1Ph Operators
K72-12510	Limit Switch
K75-12511	Limit Shaft

NOTE: Single Phase units are equipped with an external line break device and may be equipped with an additional internal pilot duty thermal O/L device. Three phase units may be equipped with an internal pilot duty thermal O/L device or an external line break device. Items without part numbers are not available for individual purchase.

ELECTRICAL BOX

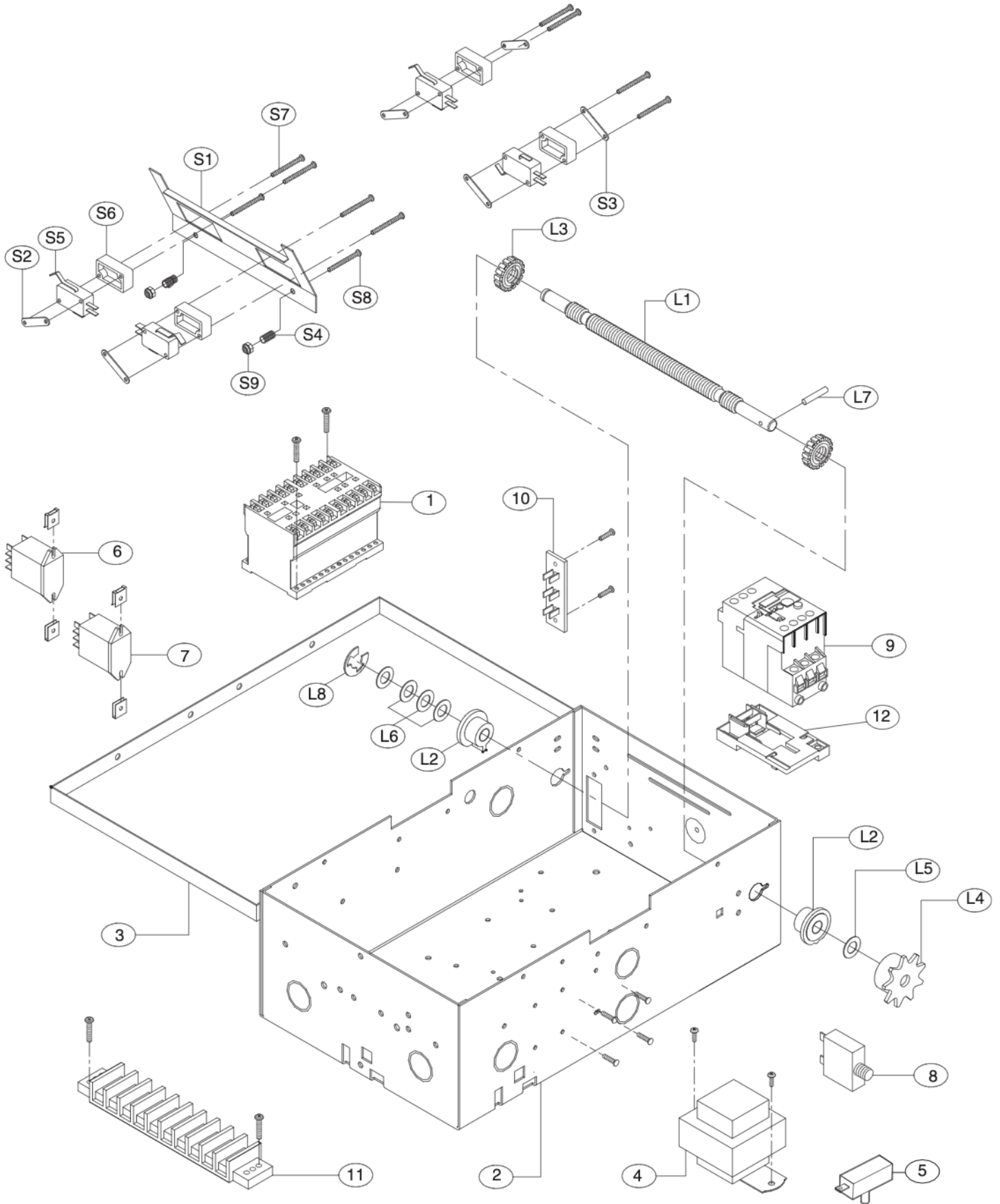

REPAIR PARTS KITS - MODEL GH

Refer to the parts lists below for replacement kits available for your operator. If optional modifications and/or accessories are included with your operator, certain components may be added or removed from these lists. Individual components of each kit may not be available. Please consult a parts and service representative regarding availability of individual components. Refer to page 11 for all repair part ordering information.

SERVICE KITS

ITEM	PART#	DESCRIPTION	QTY
K1	K75-12584	Brake Kit, 115 Volt Models	1
	K75-12585	Brake Kit, 230-460 Volt Models	1
	K75-12586	Brake Kit, 575 Volt Models	1
		Complete with: Brake Hub Kit, Brake Release Lever, Brake Disk, Spring Cup, Studs, Compression Springs, Brake Solenoid, Solenoid Cover, Spacers, Mounting Plate, Pressure Plate, Feather Key and Fastener.	
K2	K75-10177	Brake Hub Kit	1
		Complete with: Brake Hub, Set Screw, Push on Fastener and Feather Key.	
K3	K72-12789	Hand Chain Shaft Kit (1/2-2HP)	1
	K75-14661	Hand Chain Shaft Kit (3 HP)	1
		Complete with: Bevel Gear 5/8" ID, Bevel Gear 3/4" ID, Hand Chain Guide, Hand Chain Shaft, Bearing 3/4" ID, Nylon Bearing, Compression Spring, Chain Wheel, Washers, Roll Pins and E-Rings.	
K4	K75-30737	Disconnect Kit	1
		Complete with: Switch Assembly GH Interlock, Disconnect Lever, Bevel Gear Yoke, Brake Release, Actuator Bracket, Switch Actuator, Disconnect Shaft, Tension Spring, Sash Chain with Keyring, Screws, Nuts, Flatwashers, Lockwashers, Cotter Pins and Roll Pin.	
K5	K75-12829	Gear Housing Kit (1HP, 115 Volts)	1
	K75-12830	Gear Housing Kit (1HP, 230-460 Volts)	1
	K75-12831	Gear Housing Kit (1HP, 575 Volts)	1
	K75-12832	Gear Housing Kit (1.5-2HP, 230-460 Volts)	1
	K75-12833	Gear Housing Kit (1.5-2HP, 575 Volts)	1
		Complete with: Housing Support Bracket, Pads and Pressure Plate, Housing with Cover, Disconnect Kit, Hand Chain Shaft and Brake Kit.	

INDIVIDUAL PARTS

ITEM	PART#	DESCRIPTION	QTY
1	22-120	Brake Solenoid, 115 Volt	1
	22-240	Brake Solenoid, 230-460 Volt	1
	22-575-1	Brake Solenoid, 575 Volt	1
2	80-9001	Feather Key	1
3	32-11009	Gear Reducer (1/2-1HP, 45:1)	1
	32-11010	Gear Reducer (1.5-2HP, 44:1)	1
	32-11011	Gear Reducer (3HP, 42:1)	1
4	15-48B18LGE	Sprocket, 48B18 LGE (1/2-1HP)	1
	15-48B18PJH	Sprocket, 48B18 PJH (1.5-2HP)	1
	15-48B18QGH	Sprocket, 48B18 (3HP)	1
5	15-50B12LGH	Sprocket, 50B12 LGH 1" (1/2-1HP)	1
	15-50B12PJH	Sprocket, 50B12 PJH 1 3/16" (1.5-2HP)	1
	15-80B9QGH	Sprocket, 80B9 1 1/4" (3HP)	1
6	10-11021	Disconnect Lever	1
7	19-8A-12	Sash Chain, 12' with Keyring	1
8	08-11012	Bevel Gear, 5/8" ID	1
	75-13334	Bevel Gear, 3/4" I.D. (3HP)	1
9	08-11013	Bevel Gear, 3/4" I.D.	1
	08-13333	Bevel Gear, 3/4" I.D. 24 tooth (3HP)	1
10	10-10882	Hand Chain Guide	1
11	12-10883	Nylon Bearing	1
12	11-11105	Hand Chain Shaft	1
13	12-10029	Bearing, 3/4" I.D.	2
14	18-11008	Compression Spring	1
15	75-10884	Chain Wheel Assembly	1
16	74-30731	Switch Assembly GH Interlock	1

MODEL GH

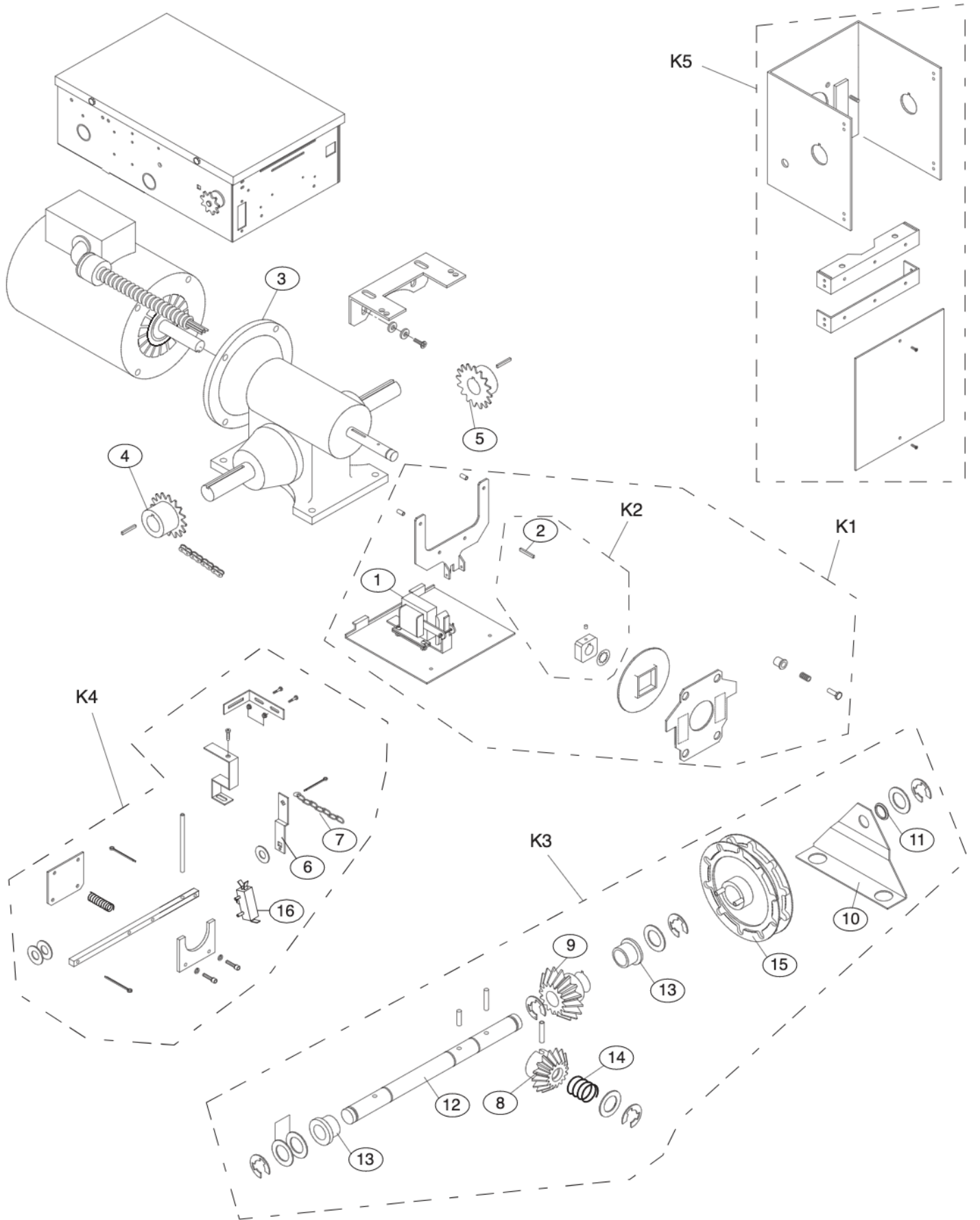

CONTROL CONNECTION DIAGRAM

IMPORTANT NOTES:

- 1) The 3-Button Control Station provided must be connected for operation.
- 2) If a STOP button is not used, a jumper must be placed between terminals 3 and 4.
- 3) Auxiliary control equipment may be any normally open two wire device such as pullswitch, single button, loop detector, card key or such device.

ATTENTION ELECTRICIAN:
USE 16 GAUGE OR HEAVIER WIRE
FOR ALL CONTROL CIRCUIT WIRING.

